

## Highlights

- Silicon-MEMS thermal mass flow sensor
- Firmware running on a standard microcontroller delivers digital flow and differential pressure sensing solutions
- Fully temperature-compensated readings
- Measures to 500 slm or more in bypass flow configurations
- Firmware-programmable operating modes and features
- Ultra-small surface mount package
- Fully compatible with SMD assembly processes



6-pin DFN package  
3.5 mm × 3.5 mm footprint  
3 mm overall height

FLS110 is suitable for high-volume consumer products and high-precision medical or industrial applications. It will add value to your product whether you are trying to detect an obstruction or monitor a flow profile in detail. The FLS110 is very versatile, and our digital integration solution gives you the flexibility to optimise performance-cost ratio in your application.

## Digital flow sensing solutions with FLS110

The FLS110 has two analogue sensing elements integrated in a MEMS die: a tungsten wire for sensing flow and a temperature sensor. Firmware provided by Flusso, running on a standard microcontroller, drives the sensing elements, digitises their response to mass flow through the FLS110 and calculates readings for:

- Flow temperature
- Mass flow – using the principle of hot-wire anemometry
- Volumetric flow or differential pressure (DP) – when given flow pressure by the host application

Figure 1 illustrates a system with the FLS110 in a flow bypass configuration and the firmware running on a dedicated microcontroller. Application software on the host processor controls the FLS110 firmware and obtains readings using write and read transactions over a serial digital interface (typically I<sup>2</sup>C-bus®).

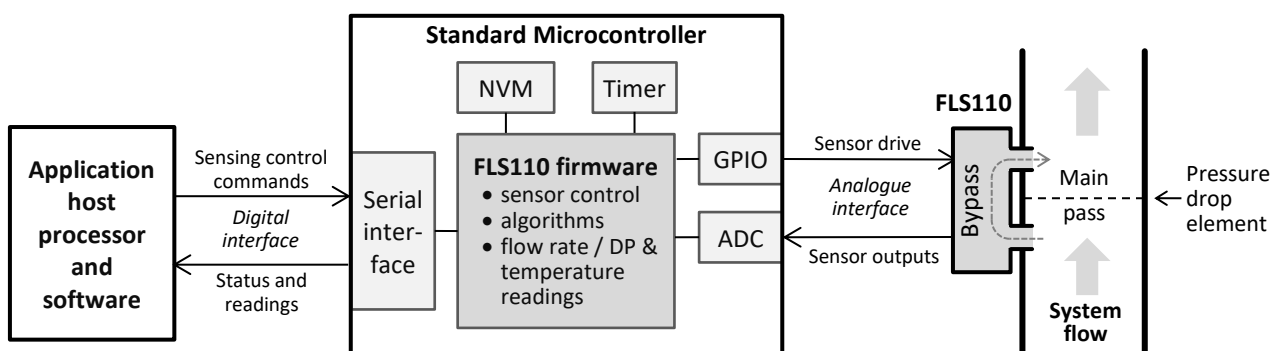

Figure 1: Example of an FLS110 flow sensing solution with dedicated microcontroller

The FLS110 firmware can also be compiled and linked with application code to run on a single, shared microcontroller. The application then uses API calls instead of the serial interface.

By virtue of system-level flow characterisation during end-product development, or calibration of individual product units, FLS110 firmware calculates and reports **system flow**, i.e., not just the flow through the bypass and FLS110 itself.

Calibration functions supported in the firmware enable straightforward optimisation of FLS110 flow sensing algorithms to your system characteristics and sensing accuracy requirements.

Refer to *Developing Your Flow Sensing Solution with FLS110* for a more extensive overview of FLS110 flow sensing solutions and how you can rapidly implement them in your product design.

## 1 Sensing performance

Unless otherwise stated, sensing performance is specified at mean  $\pm 3\sigma$  under these standard conditions:

- A through-flow system configuration (see section 2)
- FLS110-STM32 reference design sensor module with VDD = 3.3 V (see section 5)
- Ambient temperature  $T_{amb}$  and flow temperature  $T_{flow}$  of 25 °C
- FLS110 standard firmware operating in Continuous mode with averaging over 8 measurements
- Clean air with flow pressure  $p_{flow} = 101.3$  kPa and relative humidity  $\phi_{flow} = 0$  %
- Flow temperature sensor offset determined at  $T_{ref} = 25$  °C (see section 5.6.1)
- Three-point system calibration (see section 5.6.2)

### 1.1 Mass flow readings

The unit of mass flow adopted for performance specification is the standard cubic centimetre per minute (sccm), with standard conditions defined as  $T_{flow} = 25$  °C and  $p_{flow} = 101.3$  kPa. Span accuracy and repeatability are specified over the nominal operating range 4 sccm to 200 sccm full scale (f.s.). Operation outside this range is safe, subject to Absolute maximum ratings specified in section 4. Below 4 sccm the effects of device orientation and inlet conditions in the application are unpredictable.

Parameter		Max	Units	Note
Repeatability	Zero flow	0.5	sccm	Equivalent to 0.25 % of full scale (f.s.)
	Span > 4 sccm	0.5	% m.v.	% of measured value
Accuracy	Zero flow	1	sccm	Equivalent to 0.5 % of full scale (f.s.)
	Span	$\pm 5$	% m.v.	% of measured value
Temperature dependence	Zero flow	$\pm 0.2$	sccm/°C	
	Span	$\pm 0.05$	% m.v./°C	Multiply by $ T_{ref} - T_{flow} $ in °C

### 1.2 Differential pressure (DP) readings

Span accuracy and repeatability are specified over the nominal operating range 0 Pa to 500 Pa full scale (f.s.). Operation outside this range is safe, subject to Absolute maximum ratings specified in section 4.

Parameter		Max	Units	Note
Repeatability	Zero DP	0.5	Pa	Equivalent to 0.1 % of full scale (f.s.)
	Span	1	% m.v.	% of measured value
Accuracy	Zero DP	1	Pa	Equivalent to 0.2 % of full scale (f.s.)
	Span	$\pm 5$	% m.v.	% of measured value
Temperature dependence	Zero DP	$\pm 0.2$	Pa/°C	
	Span	$\pm 0.05$	% m.v./°C	Multiply by $ T_{ref} - T_{flow} $ in °C

### 1.3 Flow temperature ( $T_{flow}$ ) readings

Typical performance is specified for

- $T_{flow} = T_{amb}$  stable in the range -20 °C to +85 °C (equilibrium conditions).
- Mass flow in the range 0 sccm to 200 sccm and differential pressure in the range 0 Pa to 500 Pa.

Note: flow temperature measurements are affected by the thermal environment in your product.

Parameter		Typ	Units	Note
Repeatability		0.5	°C	
Accuracy	At $T_{flow} = T_{ref}$	$\pm 2$	°C	See section 5.6.1
	Span	$\pm 3$	% m.v./°C	Multiply by $ T_{ref} - T_{flow} $ in °C

## 2 System flow path configurations

The FLS110 can be applied in through-flow or bypass system configurations, illustrated in Figure 2.

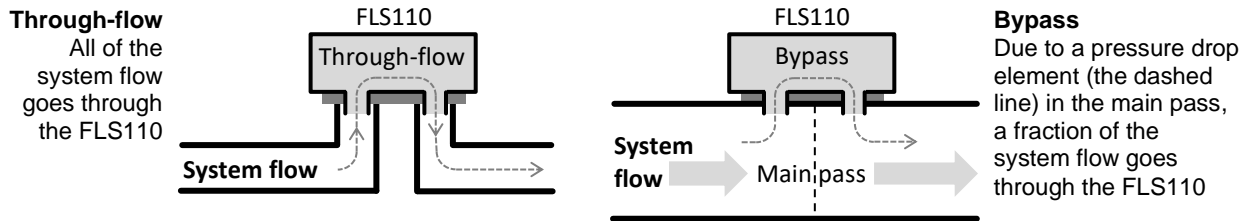

Figure 2: Through-flow and bypass system configurations

Flow and DP sensing performance is specified in section 1 for a through-flow configuration. Corresponding performance can be achieved in bypass configurations with much higher system flow rates. Technical note *Mechanical and Fluidic Integration of the FLS110* gives guidance for integrating FLS110 into your flow path.

## 3 Normal operating conditions

Device reliability might be compromised if the FLS110 is operated outside the conditions specified in Table 1.

Table 1: Normal operating conditions

Parameter	Symbol	Min	Max	Units	Notes
Flow pressure	$p_{flow}$	70	125	kPa	Absolute pressure
Ambient temperature	$T_{amb}$	-20	+85	°C	
Flow temperature	$T_{flow}$	-20	+85	°C	
Humidity in the flow	$\phi_{flow}$		90	%RH	Non-condensing
Gas in flow	Air. Contact Flusso for information about sensing flow of other gases.				

## 4 Absolute maximum ratings

Permanent damage might result from exposure to conditions in excess of those specified in Table 2. FLS110 is not qualified for sensing liquid flow. Liquids will cause permanent damage to the device.

Table 2: Absolute maximum ratings

Parameter	Symbol	Min	Max	Units	Notes
Storage temperature	$T_{store}$	-40	+85	°C	
Storage humidity			90	%RH	Non-condensing
Ambient temperature	$T_{amb}$	-40	+85	°C	
Ambient humidity	$\phi_{amb}$		90	%RH	Non-condensing
Flow temperature	$T_{flow}$	-40	+85	°C	
Flow humidity	$\phi_{flow}$		90	%RH	Non-condensing
Mass flow rate	$\dot{m}$	-2000	+2000	sccm	Through-flow, from inlet port to outlet port
Differential pressure	$\Delta p$	-5000	+5000	Pa	Inlet port pressure minus outlet port pressure
Flow pressure	$p_{flow}$		200	kPa	Above ambient pressure
Voltage between pins	$V_{in}$		3.6	V	Between any two functional pins. See section 6.
Flow sensor power	$P_{FS}$		50	mW	
Electrostatic discharge			500	V	Human body model, JS-001-2017
			1000	V	Charged device model, JS-002-2018

## 5 FLS110-STM32 reference design

Sensing functionality and performance specifications (section 1) are achieved with a practical implementation of the FLS110-STM32 reference design running Flusso’s FLS110-STM32 Sensor Module Standard I2C Firmware (FL-001470-FW). Two sensor module variants are available for FLS110 Evaluation Kits:

- FL-001168-PT with an independent I<sup>2</sup>C pressure sensor fitted
- FL-001068-PT without the pressure sensor fitted

What follows is an overview of the hardware design and firmware functionality. Further information is available in technical notes *FLS110 Hardware Design Guide* and *FLS110 Firmware Integration Guide*, including how the hardware design and firmware can be tailored to your particular application requirements.

### 5.1 Hardware design

The FLS110-STM32 reference design schematic and a sensor module are shown Figure 3. The module is the FL-001168-PT with independent I<sup>2</sup>C pressure sensor fitted (not shown in schematic). The firmware runs on a STMicroelectronics™ STM32L031G6U6 microcontroller. It operates the analogue interface of the FLS110 and presents an I<sup>2</sup>C slave interface to a host via the 10-way connector. Refer to datasheet DS10668 and the STM32L0x1 Reference Manual RM0377 for full information about the processor.

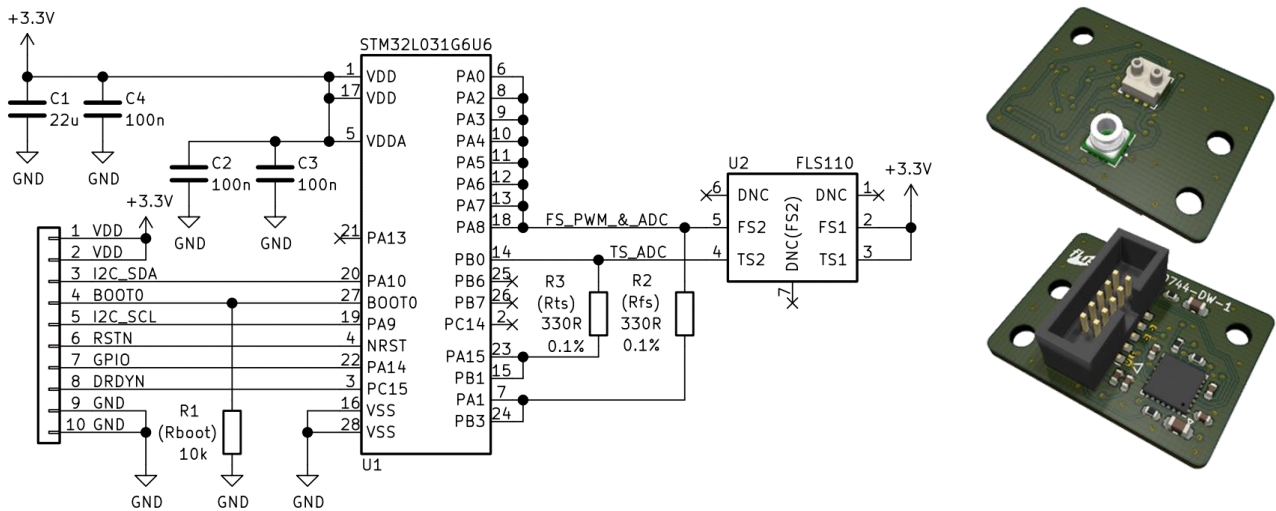

**Figure 3:** FLS110-STM32 reference design schematic and module implementation

The FLS110 flow sensor pin FS2 is pulse-driven by the firmware. To deliver the peak current requirement, a number of open-drain outputs are connected in parallel. In the FLS110-STM32 reference design seven are connected, typically four or five are sufficient. The connector pin functions are summarised in Table 3, below.

**Table 3:** FLS110-STM32 reference design connector pin definitions

Pin	Name	Description
1,2	VDD	Power supply to the module.
3	I2C_SDA	I <sup>2</sup> C-bus data. A pull-up resistor (2.2 kΩ to 4.7 kΩ) is required on the host side.
4	BOOT0	Drive high during power-up to load a firmware image over the I <sup>2</sup> C-bus
5	I2C_SCL	I <sup>2</sup> C-bus clock. A pull-up resistor (2.2 kΩ to 4.7 kΩ) is required on the host side.
6	RSTN	Pull low to reset the processor.
7	GPIO	A general-purpose IO, not used by the standard FLS110 firmware.
8	DRDYN	Open drain. Pulled low when a new reading is ready or certain firmware operations complete (see section 5.5.3). A pull-up resistor (2.2 kΩ to 4.7 kΩ) is required on the host.
9,10	GND	System ground (0 V).

### 5.2 Operating parameters

The main operating parameters of the FLS110-STM32 reference design are listed in Table 4. Some are referred to in explanations of firmware functionality in sections that follow.

**Table 4:** FLS110-STM32 reference design operating parameters

Parameter	Symbol	Min	Typ	Max	Units	Comment
Power supply	VDD	3.0	3.3	3.6	V	
Total current consumption (including the STM32L031 micro)	I <sub>DD_CONT</sub>			15	mA	Continuous or Single Shot mode
	I <sub>DD_IDLE</sub>			2	µA	In Idle mode
Power-up / reset time	t <sub>start</sub>			10	ms	After which I <sup>2</sup> C interface is ready
I <sup>2</sup> C clock (I2C_SCL) frequency	f <sub>I2C</sub>			400	kHz	Depending on application design
Time to first reading in Continuous mode or a new Single Shot reading	t <sub>FSS</sub>		56 + 4n		ms	Where n is the number of measurements being averaged
Time to next reading	t <sub>c</sub>		4		ms	In Continuous mode

### 5.3 Standard firmware I<sup>2</sup>C registers

FLS110-STM32 Sensor Module Standard I2C Firmware (FL-001470-FW) presents registers that the host can read to obtain information and write to make settings and initiate firmware functions. Table 5 on page 6 lists the registers ab further information about use of them is given in sub-sections after the table.

Figure 4 and Figure 5 illustrate write and read transactions. They follow the I<sup>2</sup>C-bus Specification and User Manual Rev. 6 nomenclature and shading conventions: transmissions from the master are shaded grey, those from the slave are unshaded. Multi-byte data values are little-endian.

- S is the I<sup>2</sup>C START condition
- The FLS110-STM32 reference design slave address is 0x31 (7 bits)
- W is a WRITE bit, value '0'
- R is a READ bit, value '1'
- P is the I<sup>2</sup>C STOP condition
- A is the ACKNOWLEDGE bit, SDA low, or NOT ACKNOWLEDGE bit, SDA high

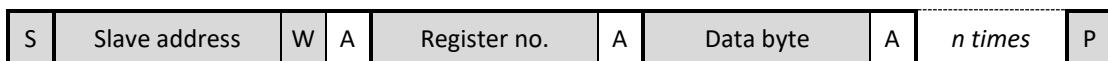

**Figure 4:** I<sup>2</sup>C Register Write of n Bytes

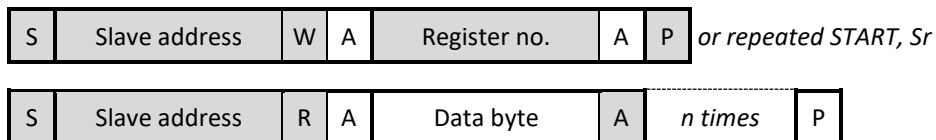

**Figure 5:** I<sup>2</sup>C Register Read of n Bytes

**Table 5:** FLS110-STM32 Sensor Module Standard I2C Firmware (FL-001470-FW) registers

The Data column gives the number of bytes transferred and the number format (U: unsigned integer, S: signed integer, F: IEEE 754 single precision floating point). Differential pressure is abbreviated as DP.

Group	Register	No.	Data	Description
<b>Static information</b> (section 5.4)	<b>FW_ID</b>	0x10	3U	<b>Read</b> 0x0F1009, the FLS110-STM32 standard firmware ID
	<b>UNIQUE_ID</b>	0x11	12U	<b>Read</b> The STM32L0 processor unique device ID
	<b>FW_BUILD</b>	0x12	4U	<b>Read</b> Firmware build number
	<b>FW_RELEASE</b>	0x13	4U	<b>Read</b> Firmware release number
<b>Firmware settings and status</b> (section 5.5)	<b>AVG_WINDOW</b>	0x20	1U	<b>Write</b> Number of measurements in a moving average window to calculate readings:1 to 128, defaults to 1. <b>Read</b> The current moving average window size.
	<b>MODE</b>	0x21	1U	<b>Write</b> Set mode 0: Idle, 1: Continuous, 2: Single Shot <b>Read</b> The current operating mode
	<b>READY</b>	0x2F	1U	<b>Read</b> Status of the latest reading or calibration step. 0: still in progress, 1: complete. See section 5.5.3.
	<b>PFLOW</b>	0xE0	4U	<b>Write</b> Flow pressure ( $p_{flow}$ ) in Pa. Defaults to 101325 Pa. <b>Read</b> The value last written, or the default if none written.
<b>Readings and sensor information</b> (section 5.6)	<b>READING</b>	0x40	4U	<b>Read</b> A system flow or DP reading x 256, in the basis and units that were selected for calibration.
	<b>H</b>	0x41	4S	<b>Read</b> Measure of heat power transfer ( $h$ ) to the flow x $2^{32}$ .
	<b>POWER</b>	0x42	4U	<b>Read</b> Power in W x $2^{32}$ dissipated by the mass flow sensor during the last measurement period ( $t_c$ ).
	<b>TFLOW</b>	0x43	2S	<b>Read</b> $T_{flow}$ in $^{\circ}C$ x 256.
<b>Offsets and system-level calibration</b> Refer to technical note <i>FLS110 System Characterisation and Calibration</i> for full information about use of these registers.	<b>TREF</b>	0xFC	2S	<b>Write</b> FLS110 device temperature $T_{ref}$ in $^{\circ}C$ x 256 to determine the $T_{flow}$ sensor offset or write 0x8000 to use the microcontroller's on-chip temperature sensor. <b>Read</b> The temperature, $T_{ref}$ in $^{\circ}C$ x 256, at which $T_{flow}$ offset was determined, or 0x8000 if not done yet.
	<b>ZEROPOINT</b>	0xF0	4U	<b>Write</b> Any value to determine the zero-point reading offset <b>Read</b> Returns 0 if zero-point offset has been determined or 0x8000 if it hasn't.
	<b>SETPOINT1</b> <b>SETPOINT2</b> <b>SETPOINT3</b>	0xF1 0xF2 0xF3	4U	<b>Write</b> 256 x the system flow or DP setpoint, which triggers a measurement <b>Read</b> The flow rate or DP setpoint x 256 that was previously written (reads 0 if none has been written)
	<b>CALIBRATE</b>	0xFF	1U	<b>Write</b> After writing to <b>SETPOINTn</b> registers, write 1 for single-point calibration or 3 for three-point calibration. $C_1$ , $C_2$ and $C_3$ are calculated from the measurements made at each setpoint. <b>Read</b> Returns the number of setpoints used (1 or 3), or an error code if calibration was unsuccessful.
	<b>C1</b> <b>C2</b> <b>C3</b>	0xC1 0xC2 0xC3	4F	<b>Write</b> The value of the coefficient to be set manually. <b>Read</b> The coefficient value previously written.
	<b>BASIS</b>	0xCB	1U	<b>Write</b> Set the basis for calculation of readings: 0 for mass flow, 1 for volumetric flow or DP. <b>Read</b> The selected basis for calculation of readings.
	<b>NOTE0</b>	0x50	4U	<b>R/W</b> Any number, used to identify calibration settings.

## 5.4 Static information

The value in the **UNIQUE\_ID** register is the concatenation of the U\_ID registers of the STM32L031G6U6 microcontroller. Refer to the STM32L0x1 Reference Manual RM0377 for further information. It is useful as a unique ID or serial number for your FLS110 flow sensor module.

The values in the **FW\_ID**, **FW\_BUILD** and **FW\_RELEASE** registers are defined in the firmware and can be customised in your build.

## 5.5 Firmware settings and status

### 5.5.1 Averaging of measurements (AVG\_WINDOW register)

The firmware can be configured to take an average over a number of measurements for calculation of readings. Averaging is applied to flow or DP readings (in the **READING** register) and flow temperature measurements (in the **TFLOW** register). It is a moving window so does not affect the update rate in Continuous mode but increases the time taken for a first or Single Shot reading to be ready ( $t_{FSS}$ ). In Idle mode, write the number of measurements to be included in the moving average to the **AVG\_WINDOW** register, up to 128.

### 5.5.2 Operating mode (MODE register)

After power-up or reset the FLS110 firmware starts in **Idle mode** - power consumption is minimised, and no flow rate or flow temperature measurements are taken. Writing 1 to the **MODE** register changes the operating mode to Continuous mode, writing 2 triggers a Single Shot reading.

In **Continuous** mode the first flow/DP and temperature readings are ready after  $t_{FSS}$ . Thereafter they are updated at intervals of  $t_c$ . The firmware stays in Continuous mode until deliberately changed.

In **Single Shot** mode new flow/DP and temperature readings are ready after  $t_{FSS}$  and the firmware automatically returns to **Idle** mode. This mode is useful for reducing average power consumption.

### 5.5.3 Operating status (READY register and DRDY signal)

Firmware operating status is available to the host by two means:

1. Polling the I<sup>2</sup>C **READY** register
2. Using the active low **DRDYN** signal to trigger an interrupt

The **READY** register reads 1 and **DRDYN** is asserted (pulled low) when

- A new flow temperature reading is ready in the **TFLOW** register (see section 5.6.1)
- A new flow or differential pressure reading is ready in the **READING** register (section 5.6.2)
- An offset or calibration step has completed  
(see technical note *FLS110 System Characterisation and Calibration*)

The **READY** register reads 0 and **DRDYN** is de-asserted (set to high impedance) when

- Entering Continuous or Single Shot mode, by writing to the **MODE** register
- Flow temperature is read from the **TFLOW** register
- System flow (or differential pressure) is read from the **READING** register
- Writing to any of the “Offset and system calibration” registers (see Table 5)

### 5.5.4 Flow pressure (PFLOW register)

Flow pressure ( $p_{flow}$ ) is used in the calculation of volumetric flow and differential pressure readings (see section 5.6.2). The FLS110 does not have a built-in flow pressure sensor, instead the host application can write flow pressure (in pascals) to the **PFLOW** register at any time.

## 5.6 Readings and sensor information

Note: Content of the **READING**, **TFLOW**, **H** and **POWER** registers is only valid when the **READY** register reads 1 and **DRDYN** is asserted, as described section 5.5. Averaging, if selected using the **AVG\_WINDOW** register, is applied to measurements to produce readings with less noise.

### 5.6.1 Flow temperature ( $T_{\text{flow}}$ ) measurement

The FLS110 has a built-in, analogue temperature sensor that is driven by the FLS110-STM32 reference design firmware via the TS2 pins (see section 5.1). Its digitised output (also at the TS2 pin) is used to:

- Provide  $T_{\text{flow}}$  readings in °C for the host application via **TFLOW** register.
- Temperature-compensate mass flow measurements (see section 5.6.2)
- Calculate volumetric flow and differential pressure readings (see section 5.6.2)

Conversion of the digitised output of the temperature sensor to Celsius (°C) or Kelvin (K) scales requires an offset term, which must be determined for every end-product unit using a simple procedure during your production test. The FLS110 must be at a known, stable temperature ( $T_{\text{ref}}$ ), which your test system software writes to the **TREF** register. Please refer to technical note *FLS110 System Characterisation and Calibration* for full information.

### 5.6.2 Flow and differential pressure readings

Readings can be calculated and provided to the host application on either **mass flow** or **volumetric flow / differential pressure basis**. Please refer to our technical note *Choosing the Measurement Basis for your FLS110 Application* for further information. The basis and units in which readings are provided is set during system-level **characterisation** or end-product unit **calibration**. This is explained in technical note *FLS110 System Characterisation and Calibration*.

The FLS110 **mass flow** sensing element is a heated wire. It is pulse-driven by a control loop in the FLS110-STM32 reference design firmware (via the FS2 pin) and maintained at a predetermined target temperature under any flow conditions. Mass flow readings are calculated as follows:

1. Heat power transfer ( $h$ ) to the flow is calculated with compensation for flow temperature ( $T_{\text{flow}}$ ).  $h$  increases with mass flow, but not linearly. A **zero-point offset** is applied so that  $h$  is zero (or very close to zero) when there is no flow through the system.
2. Mass flow ( $\dot{m}$ ) on a linear scale is calculated as a cubic function of  $h$ :

$$\dot{m} = C_3 h^3 + C_2 h^2 + C_1 h$$

The zero-point offset must be determined for every product unit, typically during your production test. Figure 6 shows the typical cubic relationship between heat power transfer to the flow ( $h$ ) and mass flow through the FLS110 ( $\dot{m}$ ) under the conditions specified in section 1.

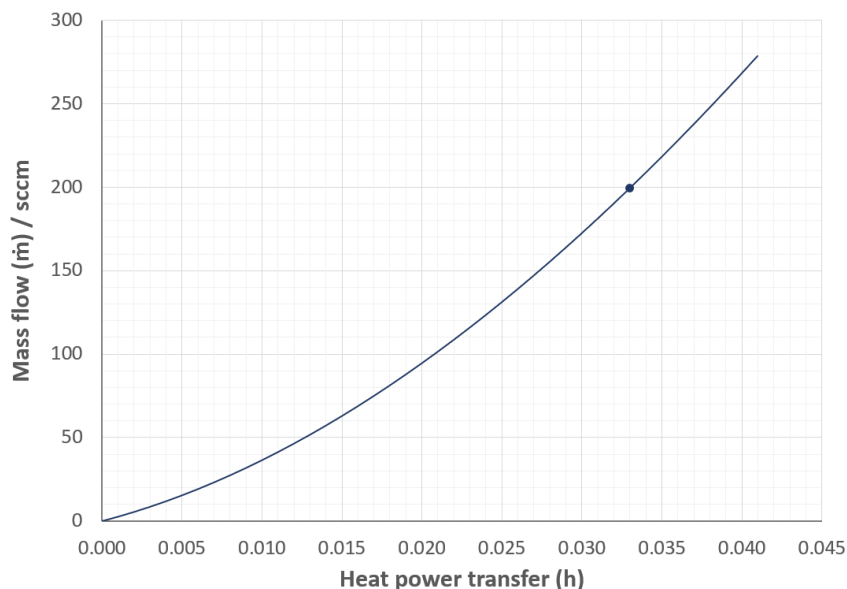

**Figure 6:** Typical relationship between mass flow ( $\dot{m}$ ) through the FLS110 and heat power transfer ( $h$ )

Procedures for determination of the zero-point offset and calibration to determine the coefficients of the cubic function are explained in technical note *FLS110 System Characterisation and Calibration*. The procedures are fully supported in the FLS110 firmware and are the same for through-flow and bypass configurations.



Mass flow sensing accuracy is specified for the FLS110-STM32 reference design in a through-flow configuration with coefficients determined by three-point calibration at 10 %, 50 % and 90 % of the full scale over which performance is specified, i.e., 20 sccm, 100 sccm and 180 sccm, using a mass flow controller.

In a bypass system configuration (see Figure 2), you would typically design the pressure drop element in your main pass for mass flow in the bypass of about 200 sccm at the highest system flow rate of interest in your application, which corresponds to  $h$  of about 0.033. Coefficients  $C_1$ ,  $C_2$  and  $C_3$  that result in **system mass flow readings** (as opposed to mass flow just in the bypass) are obtained by either:

- **System-level calibration** of each product unit, which generates optimum, unit-specific values.
- **Characterisation** of your design to generate typical or “default” values, by calibrating a number of representative prototype units and combining their respective sets of coefficients.

If **mass flow** ( $\dot{m}$ ) measurement basis was selected during determination of the zero-point offset (by writing 0 to the **BASIS** register), system mass flow ( $\dot{m}$ ) readings are made available to the host application via the **READING** register, clamped at zero. Heat power transfer ( $h$ ) is made available via the **H** register. Small negative values might be reported when flow is very close to zero because of operating conditions differing from what they were during calibration.

If **volumetric flow** ( $Q$ ) / **differential pressure** ( $\Delta p$ ) measurement basis was selected during determination of the zero-point offset (by writing 1 to the **BASIS** register), the calculation of readings takes into account the ratio of flow density when a mass flow measurement is made to what it was when the zero-point offset was determined. Gas density is proportional to pressure and inversely proportional to absolute temperature, so:

$$Q \text{ or } \Delta p = (C_3 h^3 + C_2 h^2 + C_1 h) \cdot \frac{T_{flow}}{T_0} \cdot \frac{p_0}{p_{flow}}$$

Where:

$T_0$  was the flow temperature (in kelvin) when the zero-point offset was determined.

$p_0$  was the flow pressure (in pascals) when the zero-point offset was determined.

$T_{flow}$  is the flow temperature (in kelvin), measured using the FLS110 integrated temperature sensor.

$p_{flow}$  is the flow pressure (in pascals).  $p_{flow}$  can be determined from a separate sensor in the system and provided via the **PFLOW** register or it can take a default value hard-coded in the FLS110 firmware.

Figure 7 shows the typical cubic relationship between heat power transfer to the flow ( $h$ ) and differential pressure across the FLS110 ports ( $\Delta p$ ), under the conditions specified in section 1.

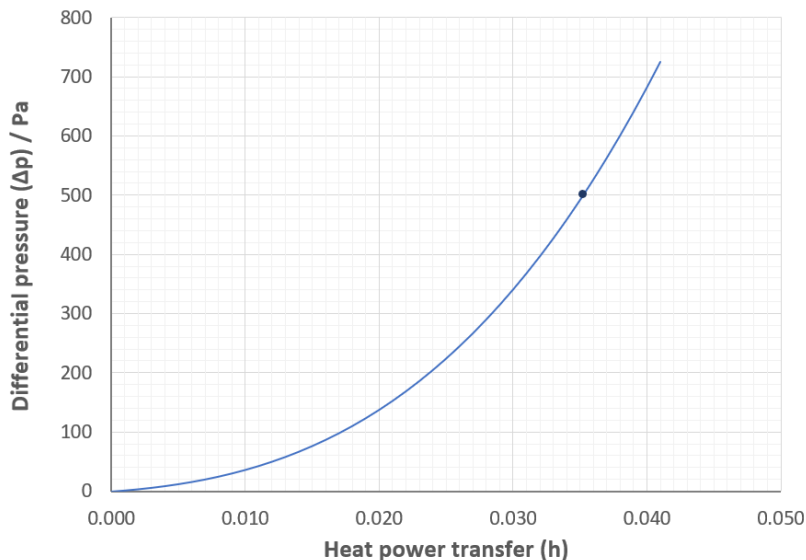

**Figure 7:** Typical relationship between differential ( $\Delta p$ ) across the FLS110 ports and heat power transfer ( $h$ )

Differential pressure sensing accuracy is specified for the FLS110-STM32 reference design (section 1.2) with coefficients determined by three-point calibration at 5 %, 50 % and 95 % of the 0 Pa to 500 Pa range over which performance is specified (i.e., 25 Pa, 250 Pa and 475 Pa). As in the case of mass flow readings, volumetric flow and DP readings are made available to the host application in the **READING** register.

**5.6.3 Mass flow sensing power consumption**

The average power dissipated by the mass flow sensing element during the last measurement period ( $t_c$ ) is made available in the **POWER** register. This information can be useful if you wish to experiment with the trade-off between power consumption and measurement rate in Single Shot mode.

**6 Pin and port assignments**

FLS110 device pin assignments and positions are shown in Table 6, below. Refer to section 5.1 and the *FLS110 Hardware Design Guide* for information about intended connection to the FLS110 pins.

**Table 6:** Pin assignments

Pin	Name	Function
1	-	Solder pad only. Do not connect.
2	FS1	Flow rate sensor connection to supply voltage.
3	TS1	Flow temperature sensor connection to supply voltage.
4	TS2	Flow temperature sensor drive connection.
5	FS2	Flow rate sensor drive connection.
6	-	Solder pad only. Do not connect.
7	-	Solder pad only. Do not connect.

FLS110 port assignments are shown in Figure 8. Flow in the reverse direction (outlet to inlet) is not damaging to the device but readings will not be as accurate.

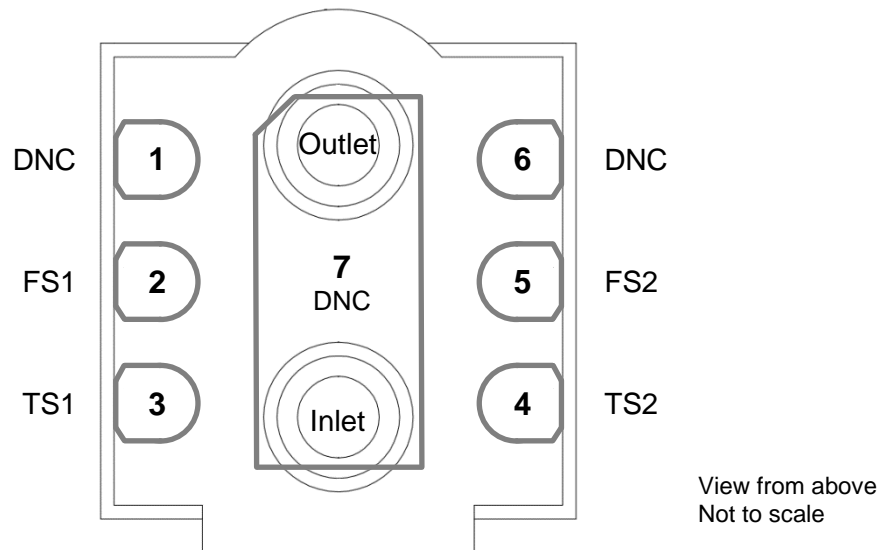

**Figure 8:** Pin and port positions

### 7 Package dimensions and marking

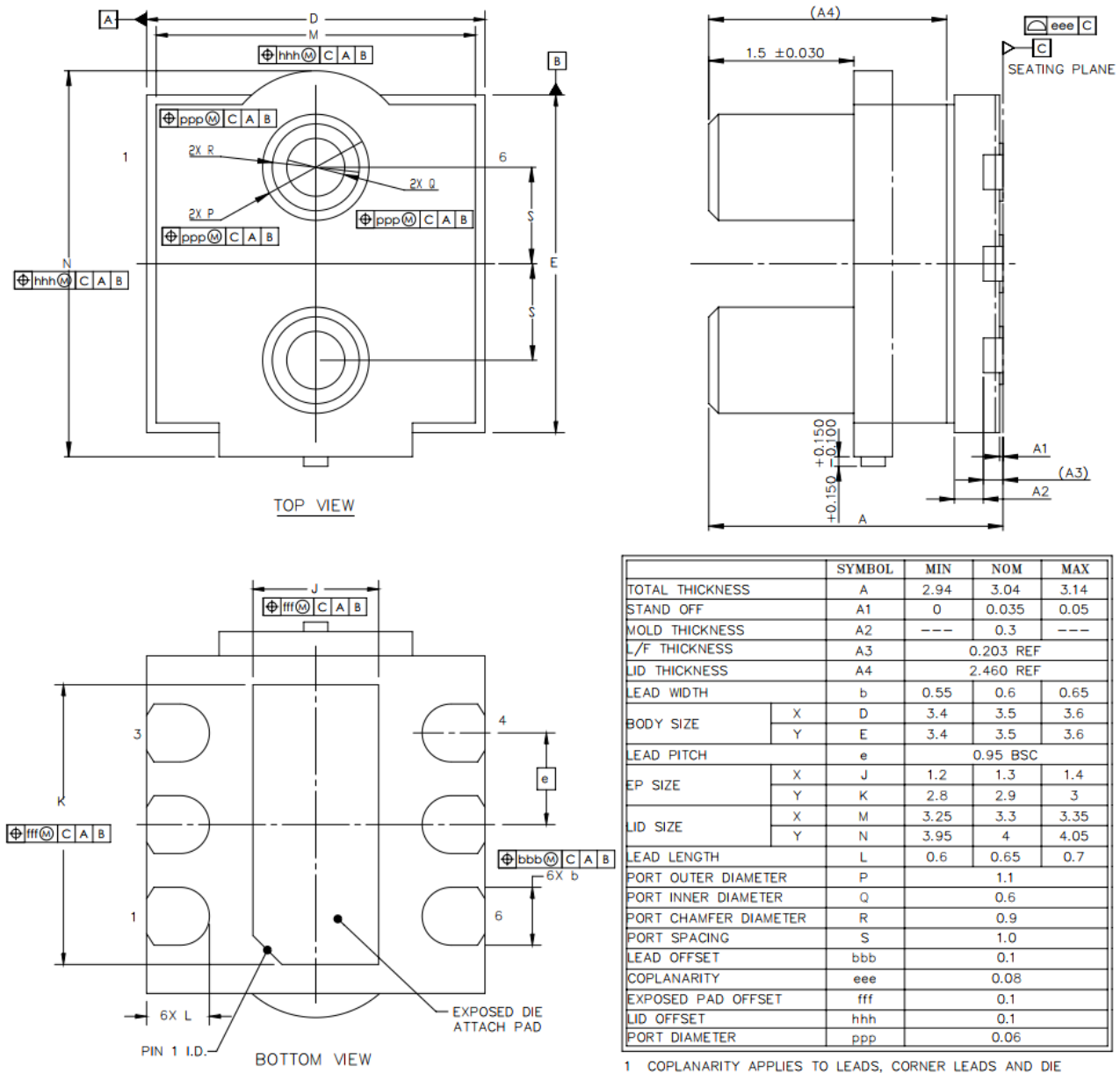

FL-001010-DW-1

Figure 9: Package dimensions

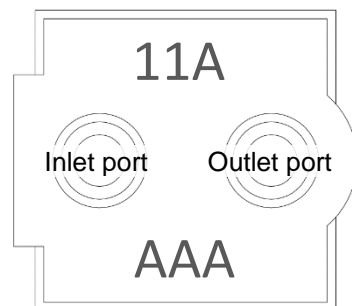

11 = FLS110 product type number  
A = assembly traceability code

Figure 10: FLS110 Package marking (not to scale) and ports

### 8 Handling and surface mount assembly

FLS110 should be handled in accordance with IPC/JEDEC J-STD-033B.1 for devices with Moisture Sensitivity Level 3.

FLS110 is supplied on tape and reel. It can be picked and placed with standard tools and equipment but vacuum should not be applied to the open ports.

Flusso recommends an IPC/JEDEC J-STD-020E Pb-Free Assembly infra-red (forced convection) reflow profile with  $T_P \leq 250\text{ }^\circ\text{C}$  and time  $t_p$  above  $245\text{ }^\circ\text{C}$  not exceeding 30 seconds. Ensure that solder and flux do not enter the FLS110 ports during reflow.

Vapour phase reflow soldering is not recommended because of the risk of contamination via the ports.

The FLS110 ports should be protected from ingress of liquid or particulate contaminants during handling and assembly processes, for example solvent cleaning, blown air cleaning and PCB singulation.

### 9 Materials

FLS110 complies with RoHS, REACH and halogen-free requirements.

### 10 Ordering and packing information

Product	Packing Type	Size	Quantity	Order code	Comment
FLS110	Tape & reel	7"	500	FLS-110-TR07	See Figure 11, below.
	Waffle tray	100 mm x 100 mm	324 (max)	FLS-110-WT324	Sample quantities only

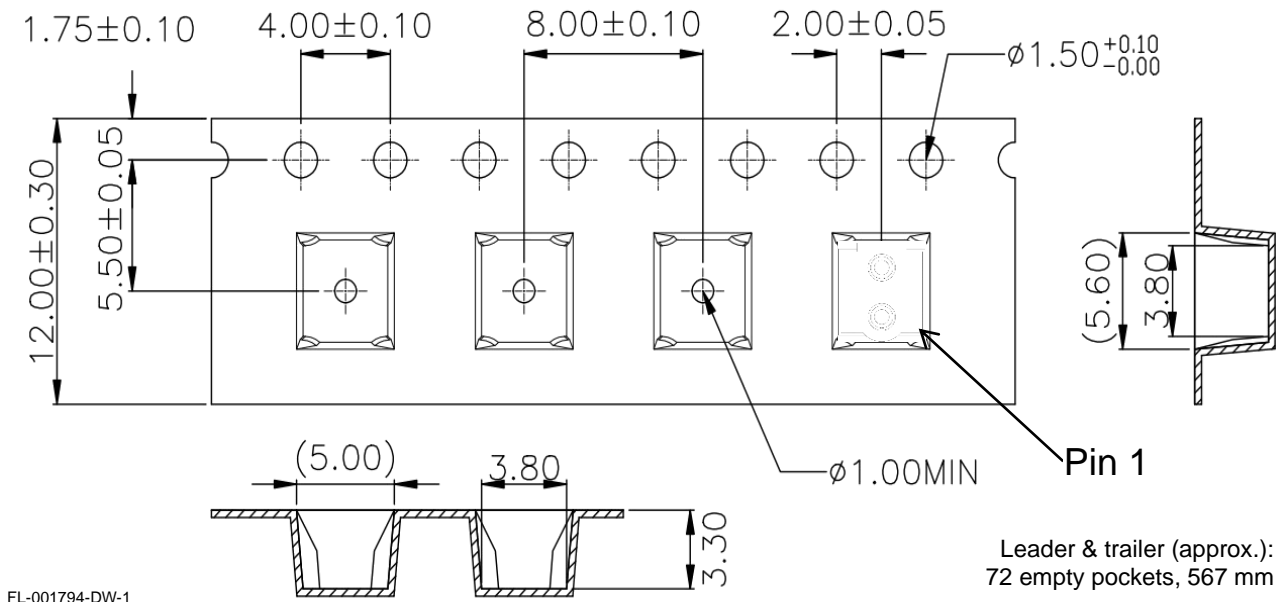

Figure 11: FLS-110-TR07 Tape Dimensions

## Datasheet Status

The status of this datasheet is shown in the footer. Please visit [www.flussold.com](http://www.flussold.com) to obtain the most recently issued version and other product information.

Datasheet Status	Product Status	Datasheet Content
Preview	Development	Target specifications for development of the product. Specifications, designs, and descriptions provisional and subject to confirmation. Flusso reserves the right change specifications or discontinue development of the product without notice.
Preliminary	Qualification	The product is undergoing testing to confirm datasheet specifications for functionality, performance, quality, and reliability. Flusso reserves the right change specifications or discontinue development of the product without notice.
Product	Production	Information and specifications for the product. Flusso reserves the right to make changes without notice for product improvement.

## Notices and disclaimers

The product information provided herein is believed to be accurate and is provided on an “as is” basis. Flusso Limited (Flusso) assumes no responsibility or liability for the direct or indirect consequences of use of the information in respect of any infringement of patents or other rights of third parties. Flusso does not grant any licence under its patents or intellectual property rights or the rights of other parties.

Application designs described herein are for illustrative purposes only. In respect of any application of the product Flusso expressly disclaims all warranties of any kind, whether express or implied, including, but not limited to, the implied warranties of merchantability, fitness for a particular purpose and non-infringement of third-party rights. No advice or information, whether oral or written, obtained from Flusso shall create any warranty of any kind. Flusso shall not be liable for any direct, indirect, incidental, special, consequential, or exemplary damages, howsoever caused including but not limited to, damages for loss of profits, goodwill, use, data, or other intangible losses.

The products and application designs described herein are subject to the conditions of use and end application exclusions as defined in Flusso Terms and Conditions of Use available upon request at [sales@flussold.com](mailto:sales@flussold.com).

This product is not intended for use in safety critical applications where failure of the product could result in personal injury (including death). Do not use this product for applications other than its intended and authorised use. Before using this product, please consult the latest datasheet, technical notes and application notes available at [www.flussold.com](http://www.flussold.com).